

STAMFORD
AvK



Compatible with STAMFORD voltage regulator.

Specialist in AVR

SX460



AS440



MX321



SX440



MX450



MX341



AS440 AUTOMATIC VOLTAGE REGULATOR (AVR)

SPECIFICATION INSTALLATION AND ADJUSTMENTS

General description

AS440 is a half wave phase controlled thyristor type AVR and forms part of the excitation system for a brushless generator. The design employs Surface Mount Technology (SMT) for high integration of features in a small footprint AVR.

Positive voltage build up from residual levels is ensured by the use of efficient semiconductors in the power circuitry of the AVR. The power and voltage sensing circuits have separate terminals, allowing the excitation power to be derived directly from the stator winding for basic applications or from an auxiliary winding if sustained short circuit performance is required.

The AVR is linked with the main stator windings and the exciter field windings to provide closed loop control of the output voltage with load regulation of +/- 1.0%.

The AVR voltage sensing terminals continuously sample the output windings for voltage control purposes. In response to this sample voltage, the AVR controls the power fed to the exciter field, and hence the main field, to maintain the machine output voltage within the specified limits, compensating for load, speed, temperature and power factor, of the generator.

A frequency measuring circuit continually monitors the generator output and provides under-speed protection of the excitation system, by reducing the output voltage proportionally with speed below a pre-settable threshold. A manual adjustment is provided for factory setting of the under frequency roll off point, (UFRO). This can easily be changed to 50 or 60 Hz in the field by push-on link selection.

Over excitation conditions are limited to a safe period by a protection circuit within the AVR.

Provision is made for the connection of a remote voltage trimmer, allowing the user fine control of the generator's output.

An analogue input is provided allowing connection to the Power Factor controller or other external devices with compatible output.

The AVR has the facility for droop CT connection, to allow parallel running with other similarly equipped generators.

Technical specification

SENSING INPUT

Voltage	Jumper selectable 100-130 Vac 1 phase or 190-264 Vac 1 phase
Frequency	50-60 Hz nominal

POWER INPUT

Voltage	100-264 V ac 1 phase
Frequency	50-60 Hz nominal

OUTPUT

Voltage	82 V d.c. @ 200 V a.c.
Current	continuous 4A (see note 1), transient 7.5A for 10 secs.
Resistance	15 ohms min (10 ohms min when input volts is less than 175 ac)

REGULATION

+/- 1.0% (see note 2)

THERMAL DRIFT

0.03% per deg. C change in AVR ambient (see note 3)

TYPICAL SYSTEM RESPONSE

AVR response	20 ms
Filed current to 90%	80 ms
Machine Volts to 97%	300 ms

EXTERNAL VOLTAGE ADJUSTMENT

+/-10% with 1 k ohm 1 watt trimmer (see note 4)
Increasing resistance lowers voltage.

UNDER FREQUENCY PROTECTION

Set point 94 -98% Hz (see note 5)

UNIT POWER DISSIPATION

12 watts maximum

BUILD UP VOLTAGE

4 Volts @ AVR terminals

ANALOGUE INPUT

Maximum input +/- 5 Vdc (see note 6)
Sensitivity 1V for 5% Generator Volts (adjustable)
Input resistance 1k ohm

QUADRATURE DROOP INPUT

10 ohms burden
Max. sensitivity: 0.07 A for 5% droop 0PF
Max. input: 0.33 A

OVER EXCITATION PROTECTION

Set point 75 V dc
Time delay 10-15 seconds (fixed)

ENVIRONMENTAL

Vibration	20-100 Hz	50mm/sec
	100Hz – 2kHz	3.3g
Operating temperature	-40 to +70C (note 7)	
Relative Humidity	0-70C 95% (note 8)	
Storage temperature	-55 to +80C	

NOTES

1. De-rate by 12% if mounted in 'portrait' orientation.
2. With 4% engine governing.
3. After 2 minutes.
4. Generator de-rate may apply. Check with factory.
5. Factory set, semi-sealed, jumper selectable.
6. Any device connected to the analogue input must be fully floating (galvanically isolated from ground), with an insulation strength of 500V ac.
7. De-rate output current by 5% per degree C above 60C.
8. Non condensing.

DESIGN DETAIL

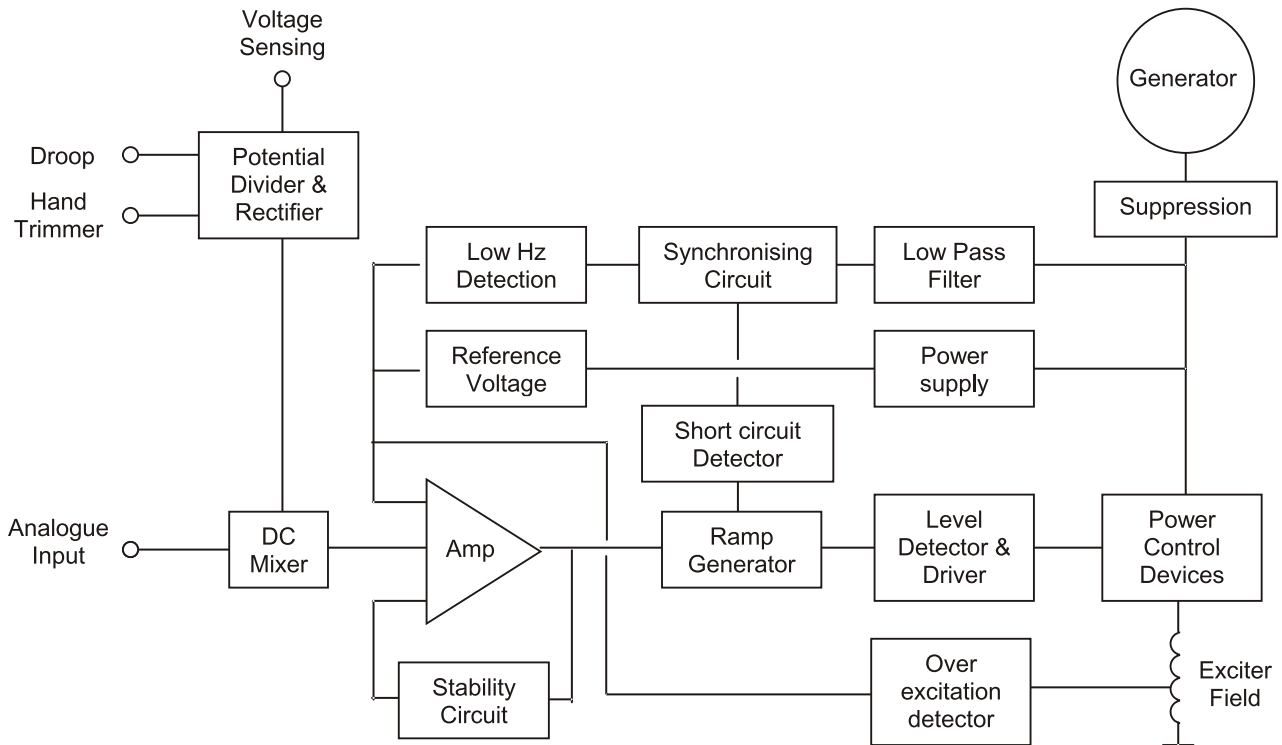

The main functions of the AVR are:

The Potential Divider and Rectifier takes a proportion of the generator output voltage and attenuates it. The potential divider is adjustable by the AVR Volts potentiometer and external hand trimmer (when fitted). The output from the droop CT is also added to this signal. A rectifier converts the a.c. input signal into d.c. for further processing.

The DC Mixer adds the Analogue input signal the Sensing signal.

The Amplifier (Amp) compares the sensing voltage to the Reference Voltage and amplifies the difference (error) to provide a controlling signal for the power devices. The Ramp Generator and Level Detector and Driver infinitely control the conduction period of the Power Control Devices and hence provides the excitation system with the required power to maintain the generator voltage within specified limits.

The Stability Circuit provides adjustable negative ac feedback to ensure good steady state and transient performance of the control system.

The Low Hz Detector measures the period of each electrical cycle and causes the reference voltage to be reduced approximately linearly with speed below a presettable threshold. A Light Emitting Diode gives indication of underspeed running.

The Synchronising circuit is used to keep the Ramp Generator and Low Hz Detector locked to the generator waveform period.

The Low Pass Filter prevents distorted waveforms affecting the operation of the AVR control circuit.

The Short Circuit Detector senses the presence of a short circuit on the generator output and forces the Power Control Devices into full conduction. This only occurs when the AVR is powered from an auxiliary winding.

Power Control Devices vary the amount of exciter field current in response to the error signal produced by the Amplifier.

Suppression components are included to prevent sub cycle voltage spikes damaging the AVR components and also to reduce the amount of conducted noise on the generator terminals.

The Over Excitation Detector continuously monitors the exciter field voltage and provides signals, to collapse the output voltage if an over excitation condition persists for the specified time period.

The Power Supply provides the required voltages for the AVR circuitry.

FITTING AND OPERATING

REFER TO GENERATOR WIRING DIAGRAM FOR CONNECTION DETAILS

Hand trimmer terminals. Remove link before fitting hand trimmer. Link must be fitted when hand trimmer is not required.

Stability Selection Table

No.	Power range	Response
B-D	< 100kW	Slow
A-C	< 100kW	Fast
B-C	100-550kW	Fast
A-B	> 550kW	Fast

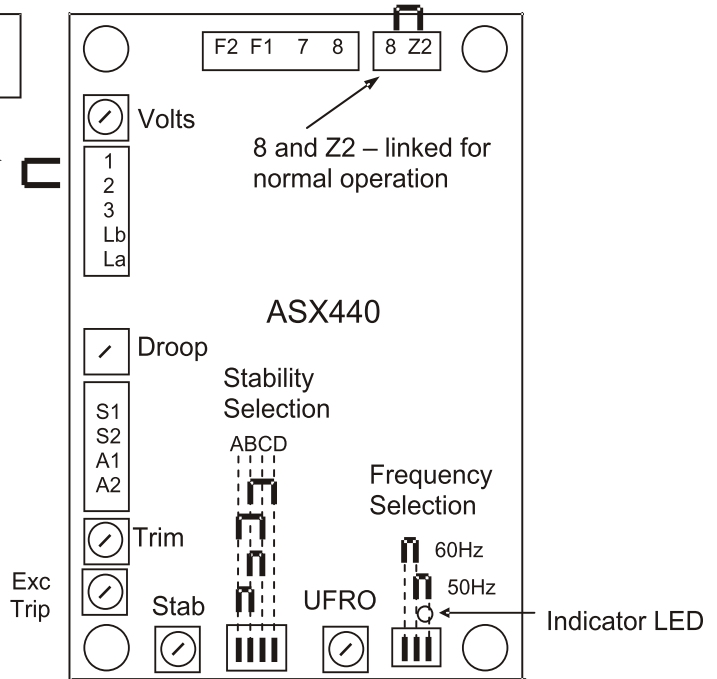

SUMMARY OF AVR CONTROLS

CONTROL	FUNCTION	DIRECTION
VOLTS	TO ADJUST GENERATOR OUTPUT VOLTAGE	CLOCKWISE INCREASES OUTPUT VOLTAGE
STABILITY	TO PREVENT VOLTAGE HUNTING	CLOCKWISE INCREASE THE DAMPING EFFECT
STAB SWITCH	TO OPTIMISE TRANSIENT PERFORMANCE	SEE TABLE ABOVE
UFRO	TO SET THE UFRO KNEE POINT	CLOCKWISE REDUCES THE KNEE POINT FREQUENCY
DROOP	TO SET THE GENERATOR DROOP TO 5% AT 0PF	CLOCKWISE INCREASES THE DROOP
VTRIM	TO OPTIMISE ANALOGUE INPUT SENSITIVITY	CLOCKWISE INCREASES THE GAIN OR SENSITIVITY
EXC TRIP	TO SET OVER EXCITATION TRIP CUT OFF LEVEL	CLOCKWISE INCREASES THE CUT OFF LEVEL

ADJUSTMENT OF AVR CONTROLS

VOLTAGE ADJUSTMENT

The generator output voltage is set at the factory, but can be altered by careful adjustment of the VOLTS control on the AVR board, or by the external hand trimmer if fitted. If major adjustment is necessary or you lose stability, follow the 'VOLTAGE SETUP PROCEDURE'.

Terminals 1 and 2 on the AVR will be fitted with a shorting link if no hand trimmer is required. Terminals La and Lb are linked only for special low voltage applications.

WARNING! Do not increase the voltage above the rated generator voltage. If in doubt, refer to the rating plate mounted on the generator case.

WARNING! Do not ground any of the hand trimmer terminals as these could be above earth potential. Failure to observe this could cause equipment damage.

WARNING!

If a replacement AVR has been fitted or re-setting of the VOLTS adjustment is required, turn the VOLTS control fully anti-clockwise before running generator.

VOLTAGE SETUP PROCEDURE

For major adjustments and replacing the AVR. **Read and understand this procedure before attempting to follow it.**

1. Before running generator, turn the VOLTS control fully anti-clockwise.
2. Turn remote volts trimmer (if fitted) to midway position.
3. Turn STABILITY control to midway position.
4. Connect a suitable voltmeter (0-300V ac) across line to neutral of the generator.
5. Start generator set, and run on no load at nominal frequency e.g. 50-53Hz or 60-63Hz.
6. If the red Light Emitting Diode (LED) is illuminated, refer to the Under Frequency Roll Off (UFRO) adjustment.
7. Carefully turn VOLTS control clockwise until rated voltage is reached.
8. If instability is present at rated voltage, refer to stability adjustment, then re-adjust voltage if necessary.
9. Voltage adjustment is now completed.

FITTING AND OPERATING

STABILITY ADJUSTMENT

The AVR includes a stability or damping circuit to provide good steady state and transient performance of the generator.

A switch is provided to change the response of the stability circuit to suit different frame size generators and applications. The table shows the options available.

The slow response settings may prove helpful in reducing lamp flicker.

The correct setting of the Stability adjustment can be found by running the generator at no load and slowly turning the stability control anti-clockwise until the generator voltage starts to become unstable.

The optimum or critically damped position is slightly clockwise from this point (i.e. where the machine volts are stable but close to the unstable region).

UNDER FREQUENCY ROLL OFF (UFRO) ADJUSTMENT

The AVR incorporates an underspeed protection circuit which gives a volts/Hz characteristic when the generator speed falls below a presettable threshold known as the "knee" point.

The red Light Emitting Diode (LED) gives indication that the UFRO circuit is operating.

The UFRO adjustment is preset and sealed and only requires the selection of 50/60Hz using the jumper link.

For optimum setting, the LED should illuminate as the frequency falls just below nominal, i.e. 47Hz on a 50Hz system or 57Hz on a 60Hz system.

DROOP ADJUSTMENT

Generators intended for parallel operation are fitted with a quadrature droop C.T. which provides a power factor dependent signal for the AVR. The C.T. is connected to S1, S2 on the AVR.

The DROOP adjustment is normally preset in the works to give 5% voltage droop at full load zero power factor.

Clockwise increases the amount of C.T. signal injected into the AVR and increases the droop with lagging power factor ($\cos \phi$). With the control fully anti-clockwise there is no droop.

TRIM ADJUSTMENT

An analogue input (A1 A2) is provided to connect to a Power Factor Controller or other devices. It is designed to accept dc signals up to +/- 5 volts.

WARNING! Any devices connected to this input must be fully floating and galvanically isolated from ground, with an insulation capability of 500 Vac. Failure to observe this could result in equipment damage.

The dc signal applied to this input adds to the AVR sensing circuit. A1 is connected to the AVR 0 volts. Positive on A2 increases excitation. Negative on A2 decreases excitation.

The TRIM control allows the user to adjust the sensitivity of the input. With TRIM fully anti-clockwise the externally applied signal has no effect. Clockwise it has maximum effect.

Normal setting is fully clockwise when used with a Power Factor Controller.

OVER EXCITATION (EXC TRIP) ADJUSTMENT

The adjustment is set and sealed in the works and should not be altered.

An over excitation condition is indicated on the common LED which also indicates under speed running.

The generator must be stopped to reset an over excitation condition.



Jabbour DataKom sarl
Medawar Area
Saint Michel Street
Jabbour Bldg.
Beirut - Lebanon
Tel: + 961(0)1580758
Fax: +961(0) 1 585115
Web: www.jabbourdatakom.com
e-mail: info@jabbourpower.com

TD_AS440 AVR_09.06_02_GB

MX321 AUTOMATIC VOLTAGE REGULATOR (AVR) SPECIFICATION, INSTALLATION AND ADJUSTMENTS

General description

MX321 is a three phase sensed Automatic Voltage Regulator and forms part of the excitation system for a brush-less generator. Excitation power is derived from a three-phase permanent magnet generator (PMG), to isolate the AVR control circuits from the effects of non-linear loads and to reduce radio frequency interference on the generator terminals. Sustained generator short circuit current is another feature of the PMG system.

The AVR senses the voltage in the main generator winding and controls the excitation to maintain the generator output voltage within the specified limits, compensating for load, speed, temperature and power factor of the generator. Three phase RMS sensing is employed for superior voltage regulation.

Adjustable Soft start circuitry is included to provide a smooth controlled build up of generator output voltage.

A frequency measuring circuit continually monitors the shaft speed of the generator and provides under-speed protection of the excitation system by reducing the generator output voltage proportionally with speed below a pre-settable threshold. A further enhancement of this feature is an adjustable volts per Hertz slope and voltage recovery time, to improve the response of turbo charged engines.

Current limiting may be included to allow control over the amount of sustained short circuit current.

Maximum excitation is limited to a safe period by internal shutdown of the AVR output device. This condition remains latched until the generator has stopped.

The AVR includes an over-voltage protection feature with internal shutdown of the AVR output device, plus the ability to trip an optional excitation circuit breaker if required.

Provision is made for the connection of a remote voltage trimmer, allowing the user fine control of the generator's output.

An analogue input is provided allowing connection to a Newage Power Factor controller or other external device with compatible output.

The AVR has the facility for droop CT connection, to allow parallel running with other similarly equipped generators.

Technical specification

SENSING INPUT

Voltage 190-264V ac max, 2 or 3 phase
Frequency 50-60 Hz nominal

POWER INPUT (PMG)

Voltage 170-220V ac max, 3 phase, 3 wire
Current 3A/phase
Frequency 100-120 Hz nominal

OUTPUT

Voltage max 120V dc
Current continuous 3.7 A (see note 1)
Intermittent 6A for 10 secs.
Resistance 15 ohms minimum

REGULATION

+/- 0.5% RMS with 4% engine governing (see note 2)

THERMAL DRIFT

0.02% per deg. C change in AVR ambient (note 3)

SOFT START RAMP TIME

0.4 - 4 seconds

TYPICAL SYSTEM RESPONSE

AVR response 10 ms
Filed current to 90% 80 ms
Machine Volts to 97% 300 ms

EXTERNAL VOLTAGE ADJUSTMENT

+/-10% with 5 k ohm 1 watt trimmer (see note 4)

UNDER FREQUENCY PROTECTION

Set point 95% Hz (see note 5)
Slope 100-300% down to 30 Hz
Max. Dwell 20% volts/S recovery

UNIT POWER DISSIPATION

18 watts maximum

ANALOGUE INPUT

Maximum input +/- 5 Vdc (see note 6)
Sensitivity 1v for 5% Generator Volts (adjustable)
Input resistance 1k ohm

QUADRATURE DROOP INPUT

10 ohms burden
Max. sensitivity: 0.22 A for 5% droop 0PF
Max. input: 0.33 A

CURRENT LIMIT INPUT

10 ohms burden
Sensitivity range: 0.5 – 1A

OVER VOLTAGE DETECTOR INPUT

Set point: 300v. Time delay: 1 Sec (fixed)
CB trip coil volts: 10-30 vdc
CB trip coil resistance: 20-60 ohms

OVER EXCITATION PROTECTION

Set point 75 V dc
Time delay 8-15 seconds (fixed)

ENVIRONMENTAL

Vibration 20- 100 Hz 50mm/sec
100Hz – 2kHz 3.3g
Operating temperature -40 to +70°C
Relative Humidity 0-70°C 95% (see note 7)
Storage temperature -55 to +80°C

NOTES

1. Derate linearly from 3.7A at 50°C to 2.7A at 70°C
2. The stated voltage regulation may not be maintained in the presence of certain transmitted radio signals. Any change in regulation will fall within the limits in Criteria B of BS.EN.61000-6-2 : 2001.
3. After 10 minutes.

4. Applies to Mod status E onwards. Generator de-rate may apply. Check with factory. Factory set, semi-sealed, jumper selectable.
5. Any device connected to the analogue input must be fully floating (galvanically isolated from ground), with an insulation strength of 500V ac.
6. Non condensing.

DESIGN DETAIL

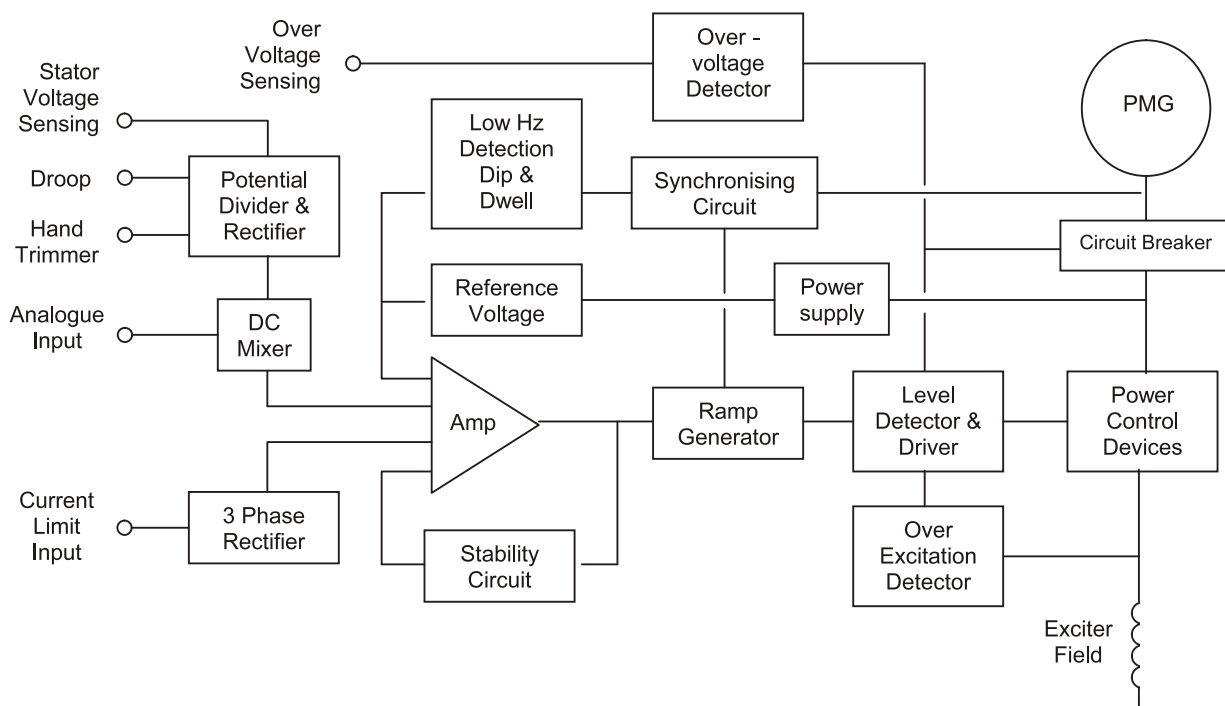

The main functions of the AVR are:

The Potential Divider and Rectifier takes a proportion of the generator output voltage and attenuates it. The potential divider is adjustable by the AVR Volts potentiometer and external hand trimmer (when fitted). The output from the droop CT is also added to this signal. A rectifier converts the a.c. input signal into a d.c. signal representing generator voltage.

The DC Mixer adds the Analogue input signal the generator voltage signal.

The 3 Phase Rectifier converts the output of the current limit CT's into a dc signal representing generator current.

The Amplifier (Amp) compares the generator voltage or current signals to the Reference Voltage and amplifies the difference (error) to provide a controlling signal for the power devices. The Ramp Generator and Level Detector and Driver infinitely control the conduction period of the Power Control Devices and hence provides the excitation system with the required power to maintain the generator voltage within specified limits.

The Stability Circuit provides adjustable negative ac feedback to ensure good steady state and transient performance of the control system.

The Power Supply provides the required voltages for the AVR circuitry.

The Low Hz Detector measures the period of each electrical cycle and causes the reference voltage to be reduced approximately linearly with speed below a presettable threshold. The Dip and Dwell circuits provide adjustments for greater voltage roll off and recovery time. A Light Emitting Diode gives indication of underspeed running.

The Synchronising circuit is used to keep the Ramp Generator and Low Hz Detector locked to the Permanent Magnet Generator waveform period.

Power Control Devices vary the amount of exciter field current in response to the error signal produced by the Amplifier.

The Circuit Breaker provides circuit isolation of the control system in the event of an over excitation or over voltage condition.

The Over Excitation Detector continuously monitors the exciter field voltage and turns off the power device if this rises above the reference level for greater than the stated time period. An external signal is also provided to trip the Circuit Breaker.

The Over Voltage Detector continuously monitors the generator stator voltage and turns off the power device if this rises above the reference level, for greater than the stated time period. An external signal is also provided to trip the Circuit Breaker.

FITTING AND OPERATING (Refer to generator wiring diagram for connection details)

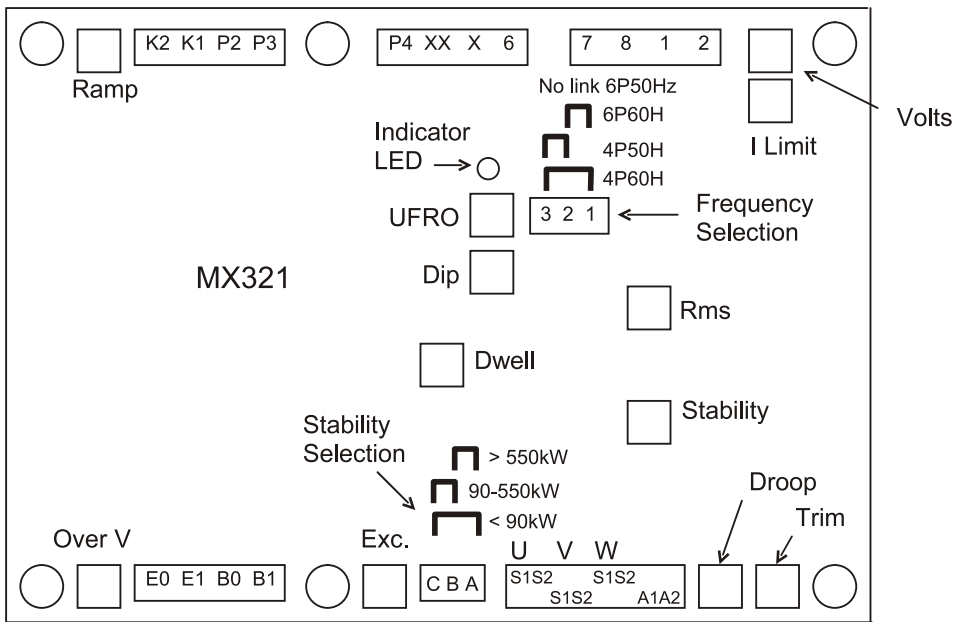

SUMMARY OF AVR CONTROLS

CONTROL	FUNCTION	DIRECTION
VOLTS	TO ADJUST GENERATOR OUTPUT VOLTAGE	CLOCKWISE INCREASES OUTPUT VOLTAGE
STABILITY	TO PREVENT VOLTAGE HUNTING	CLOCKWISE INCREASE THE DAMPING EFFECT
UFRO	TO SET THE UFRO KNEE POINT	CLOCKWISE INCREASE THE KNEE POINT FREQUENCY
DROOP	TO SET THE GENERATOR DROOP TO 5% AT 0PF	CLOCKWISE INCREASES THE DROOP
TRIM	TO OPTIMISE ANALOGUE INPUT SENSITIVITY	CLOCKWISE INCREASES THE GAIN OR SENSITIVITY
EXC	TO SET THE OVER EXCITATION TRIP LEVEL	CLOCKWISE INCREASES THE TRIP LEVEL
DIP	TO SET THE HZ RELATED VOLTAGE DIP	CLOCKWISE INCREASES THE DIP
DWELL	TO SET THE HZ RELATED RECOVERY TIME	CLOCKWISE INCREASES THE RECOVERY TIME
I LIMIT	TO SET THE STATOR CURRENT LIMIT	CLOCKWISE INCREASES THE CURRENT LIMIT
OVER V	TO SET THE OVER VOLTAGE TRIP LEVEL	CLOCKWISE INCREASES THE TRIP LEVEL
RAMP	TO SET THE NO LOAD VOLTAGE RAMP UP TIME	CLOCKWISE INCREASES THE VOLTAGE RAMP TIME

ADJUSTMENT OF AVR CONTROLS

VOLTAGE ADJUSTMENT

The generator output voltage is set at the factory, but can be altered by careful adjustment of the VOLTS control on the AVR board, or by the external hand trimmer if fitted. Terminals 1 and 2 on the AVR will be fitted with a shorting link if no hand trimmer is required.

WARNING! Do not increase the voltage above the rated generator voltage. If in doubt, refer to the rating plate mounted on the generator case.

WARNING! Do not ground any of the hand trimmer terminals, as these could be above earth potential. Failure to observe this could cause equipment damage.

If a replacement AVR has been fitted or re-setting of the VOLTS adjustment is required, proceed as follows:

1. Before running generator, turn the VOLTS control fully anti-clockwise.
2. Turn remote volts trimmer (if fitted) to midway position.
3. Turn STABILITY control to midway position.
4. Connect a suitable voltmeter (0-300V ac) across line to neutral of the generator.
5. Start generator set, and run on no load at nominal frequency e.g. 50-53Hz or 60-63Hz.
6. If the red Light Emitting Diode (LED) is illuminated, refer to the Under Frequency Roll Off (UFRO) adjustment. *Continued.....*

FITTING AND OPERATING (Refer to generator wiring diagram for connection details)

7. Carefully turn VOLTS control clockwise until rated voltage is reached.

8. If instability is present at rated voltage, refer to stability adjustment, then re-adjust voltage if necessary.

9. Voltage adjustment is now completed.

STABILITY ADJUSTMENT

The AVR includes a stability or damping circuit to provide good steady state and transient performance of the generator.

A jumper link selector is provided to optimise the response of the stability circuit to various size generators. The link should be positioned as shown in the diagram according to the kW rating of the generator.

The correct setting of the Stability adjustment can be found by running the generator at no load and slowly turning the stability control anti-clockwise until the generator voltage starts to become unstable. The optimum or critically damped position is slightly clockwise from this point (i.e. where the machine volts are stable but close to the unstable region).

UNDER FREQUENCY ROLL OFF (UFRO)

ADJUSTMENT

The AVR incorporates an underspeed protection circuit which gives a volts/Hz characteristic when the generator speed falls below a presettable threshold known as the "knee" point. The red Light Emitting Diode (LED) gives indication that the UFRO circuit is operating.

The UFRO adjustment is preset and sealed and only requires the selection of 50 or 60Hz and 4 pole or 6 pole, using the jumper link as shown in the diagram.

For optimum setting, the LED should illuminate as the frequency falls just below nominal, i.e. 47Hz on a 50Hz system or 57Hz on a 60Hz system.

DROOP ADJUSTMENT

Generators intended for parallel operation are fitted with a quadrature droop C.T. which provides a power factor dependent signal for the AVR. The C.T. is connected to S1, S2 on the AVR, (see generator wiring diagram for details). The DROOP adjustment is normally preset in the works to give 5% voltage droop at full load zero power factor.

Clockwise increases the amount of C.T. signal injected into the AVR and increases the droop with lagging power factor ($\cos \phi$). With the control fully anti-clockwise there is no droop.

TRIM ADJUSTMENT

An analogue input (A1 A2) is provided to connect to the Newage Power Factor Controller or other devices. It is designed to accept dc signals up to +/- 5 volts.

WARNING! Any devices connected to this input must be fully floating and galvanically isolated from ground, with an insulation capability of 500V ac. Failure to observe this could result in equipment damage.

TRIM ADJUSTMENT *continued*

The dc signal applied to this input adds to the AVR sensing circuit. A1 is connected to the AVR 0 volts. Positive on A2 increases excitation. Negative on A2 decreases excitation. The TRIM control allows the user to adjust the sensitivity of the input. With TRIM fully anti-clockwise the externally applied signal has no effect. Clockwise it has maximum effect.

Normal setting is fully clockwise when used with a Newage Power Factor Controller.

OVER EXCITATION (EXC) ADJUSTMENT

This adjustment is set and sealed in the works and should not be tampered with. An over excitation condition is indicated by the illumination of the red LED which also indicates under-speed running and over-volts.

The generator must be stopped to reset an over-excitation trip.

DIP ADJUSTMENT

This feature is mostly used when the generator is coupled to turbo charged engines with limited block load acceptance. The feature works by increasing the V/Hz slope to give greater voltage roll off in proportion to speed. With the DIP control fully anti-clockwise, the generator voltage will follow the normal V/Hz line as the speed falls below nominal. Turning the DIP control clockwise provides greater voltage roll off aiding engine recovery.

DWELL

This feature is mostly used when the generator is coupled to turbo charged engines with limited block load acceptance. The feature works by introducing a delay between speed recovery and voltage recovery and allows a greater DIP setting without instability. With the DWELL control fully anti-clockwise, the generator voltage will follow the V/Hz line. Turning the DWELL control clockwise increase the delay time between speed recovery and voltage recovery.

CURRENT LIMIT (I LIMIT) ADJUSTMENT

This feature is mostly used to limit short circuit current or to provide a current limit on motor starting. To use this feature, current limit CT's of the correct ratio need to be connected to the AVR S1 S2 terminals. There is an internal time limit of 10 seconds. Consult the factory before using this feature.

OVER VOLTAGE (OVER V) ADJUSTMENT

This adjustment is set and sealed in the works and should not be tampered with. An over voltage condition is indicated by the illumination of the red LED which also indicates under-speed running and over-excitation.

The generator must be stopped to reset an over-voltage trip.

RAMP

The AVR includes a soft start or voltage ramp-up circuit to control the rate of voltage build up, when the generator runs up to speed. This is normally pre-set and sealed to give a voltage ramp-up time of approximately 3 seconds. If required, this can be adjusted between the limits defined in the specification.

SX460 AUTOMATIC VOLTAGE REGULATOR (AVR)

SPECIFICATION, INSTALLATION AND ADJUSTMENTS

General description

SX460 is a half-wave phase-controlled thyristor type Automatic Voltage Regulator (AVR) and forms part of the excitation system for a brush-less generator.

In addition to regulating the generator voltage, the AVR circuitry includes under-speed and sensing loss protection features. Excitation power is derived directly from the generator terminals.

Positive voltage build up from residual levels is ensured by the use of efficient semiconductors in the power circuitry of the AVR.

The AVR is linked with the main stator windings and the exciter field windings to provide closed loop control of the output voltage with load regulation of +/- 1.0%.

In addition to being powered from the main stator, the AVR also derives a sample voltage from the output windings for voltage control purposes. In response to this sample voltage, the AVR controls the power fed to the exciter field, and hence the main field, to maintain the machine output voltage within the specified limits, compensating for load, speed, temperature and power factor of the generator.

A frequency measuring circuit continually monitors the generator output and provides output under -speed protection of the excitation system, by reducing the output voltage proportionally with speed below a pre -settable threshold. A manual adjustment is provided for factory setting of the under frequency roll off point, (UFRO). This can easily be changed to 50 or 60 Hz in the field by push - on link selection.

Provision is made for the connection of a remote voltage trimmer, allowing the user fine control of the generator's output.

Technical specification

INPUT

Voltage	Jumper selectable 95-132V ac or 190-264V ac
Frequency	50-60 Hz nominal
Phase	1

OUTPUT

Voltage	max 90V dc at 207V ac input
Current	continuous 4 A dc Intermittent 6 A for 10 secs
Resistance	15 ohms minimum

REGULATION

+/- 1.0% (see note 1)

THERMAL DRIFT

0.05% per deg. C change in AVR ambient (note 2)

TYPICAL SYSTEM RESPONSE

AVR response	20 ms
Field current to 90%	80 ms
Machine Volts to 97%	300 ms

EXTERNAL VOLTAGE ADJUSTMENT

+/-10% with 1 k ohm 1 watt trimmer (see note 3)

UNDER FREQUENCY PROTECTION

Set point	95% Hz (see note 4)
Slope	170% down to 30 Hz

UNIT POWER DISSIPATION

10 watts maximum

BUILD UP VOLTAGE

4 Volts @ AVR terminals

ENVIRONMENTAL

Vibration	20-100 Hz	50mm/sec
	100Hz 2kHz	3.3g
Operating temperature		-40 to +70 C
Relative Humidity 0-70 C		95% (see note 5)
Storage temperature		-55 to +80 C

NOTES

1. With 4% engine governing
2. After 10 minutes.
3. Applies to Mod status F onwards. Generator de-rate may apply. Check with factory.
4. Factory set, semi-sealed, jumper selectable
5. Non condensing.

DESIGN DETAIL

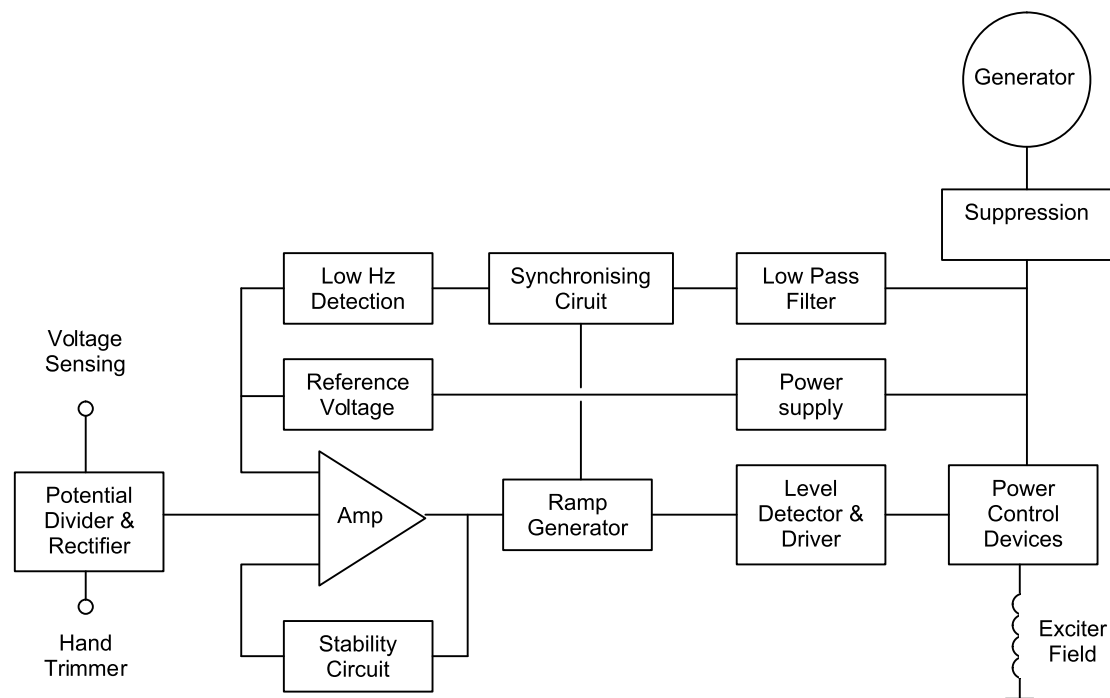

The main functions of the AVR are:

Potential Divider and Rectifier takes a proportion of the generator output voltage and attenuates it. This input chain of resistors includes the range potentiometer and hand trimmer which adjust the generator voltage. A rectifier converts the a.c. into d.c. for further processing.

The Amplifier (Amp) compares the sensing voltage to the Reference Voltage and amplifies the difference (error) to provide a controlling signal for the power devices. The Ramp Generator and Level Detector and Driver infinitely control the conduction period of the Power Control Devices and hence provides the excitation system with the required power to maintain the generator voltage within specified limits.

The Stability Circuit provides adjustable negative ac feedback to ensure good steady state and transient performance of the control system.

The Low Hz Detector measures the period of each electrical cycle and causes the reference voltage to be reduced approximately linearly with speed below a presettable threshold. A Light Emitting Diode gives indication of underspeed running.

The Synchronising circuit is used to keep the Ramp Generator and Low Hz Detector locked to the generator waveform period.

The Low Pass Filter prevents distorted waveforms affecting the operation of the AVR.

Power Control Devices vary the amount of exciter field current in response to the error signal produced by the Amplifier.

Suppression components are included to prevent sub cycle voltage spikes damaging the AVR components and also to reduce the amount of conducted noise on the generator terminals.

The Power Supply provides the required voltages for the AVR circuitry.

FITTING AND OPERATING

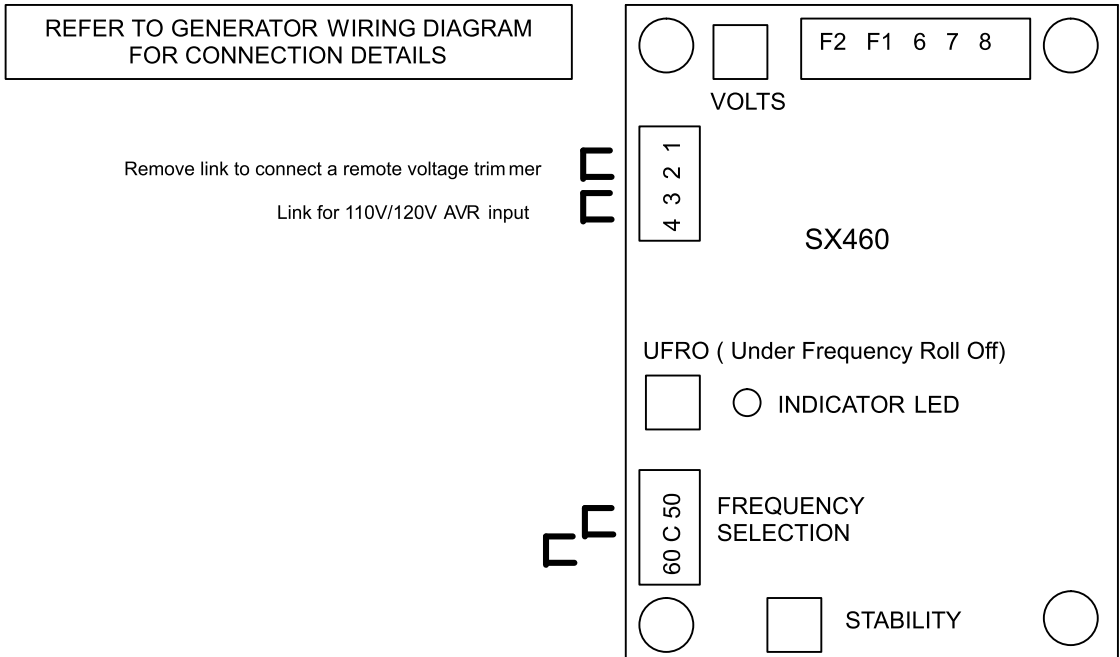

SUMMARY OF AVR CONTROLS		
CONTROL	FUNCTION	DIRECTION
VOLTS	TO ADJUST GENERATOR OUTPUT VOLTAGE	CLOCKWISE INCREASES OUTPUT VOLTAGE
STABILITY	TO PREVENT VOLTAGE HUNTING	CLOCKWISE INCREASE THE DAMPING EFFECT
UFRO	TO SET THE UFRO KNEE POINT	CLOCKWISE REDUCES THE KNEE POINT

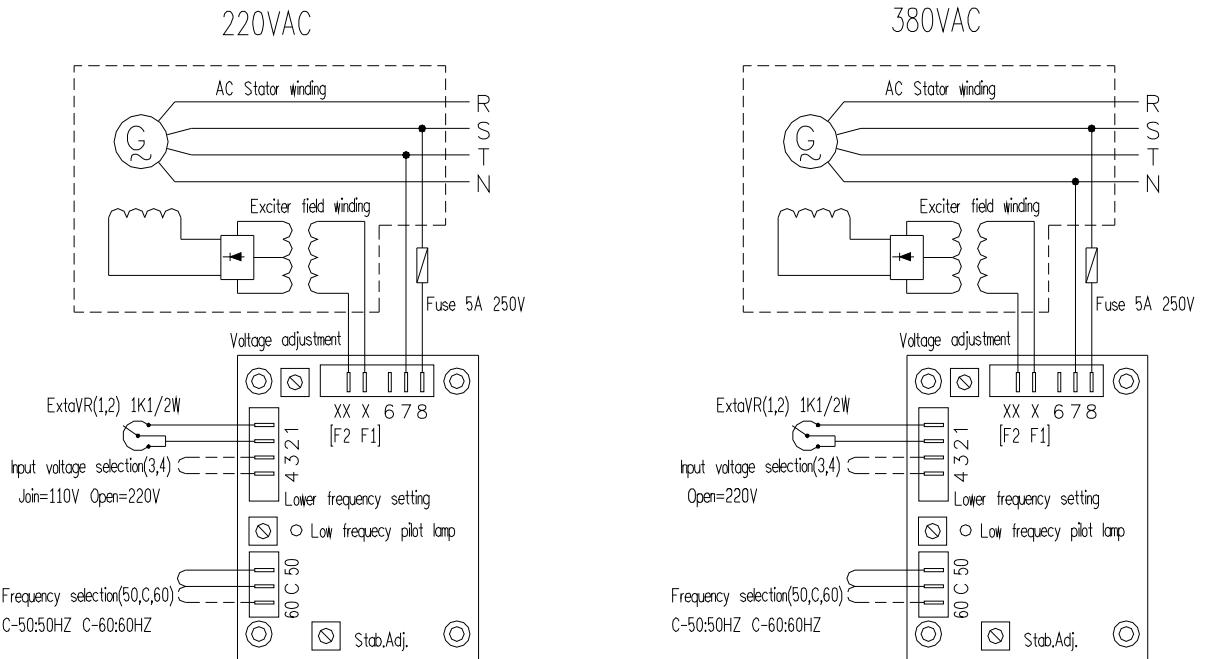

Note :

1. When there is no connection to VR, 1 and 2 must be joined.
2. When LED lamp is light on, it means the frequency isn't enough, The output voltage will decrease to prevent over load exciting current to damage the exciter field winding.

TD_SX460.GB_04.05_05_GB

ADJUSTMENT OF AVR CONTROLS

VOLTAGE ADJUSTMENT

The generator output voltage is set at the factory, but can be altered by careful adjustment of the VOLTS control on the AVR board, or by the external hand trimmer if fitted. Terminals 1 and 2 on the AVR will be fitted with a shorting link if no hand trimmer is required. Terminals 3 and 4 are linked only for special low voltage applications.

CAUTION Do not increase the voltage above the rated generator voltage. If in doubt, refer to the rating plate mounted on the generator case.

CAUTION Do not ground any of the hand trimmer terminals as these could be above earth potential. Failure to observe this could cause equipment damage.

If a replacement AVR has been fitted or re-setting of the VOLTS adjustment is required, proceed as follows:

CAUTION

1. Before running generator, turn the VOLTS control fully anti-clockwise.
2. Turn remote volts trimmer (if fitted) to midway position.
3. Turn STABILITY control to midway position.
4. Connect a suitable voltmeter (0-300V ac) across line to neutral of the generator.
5. Start generator set, and run on no load at nominal frequency e.g. 50-53Hz or 60-63Hz.
6. If the red Light Emitting Diode (LED) is illuminated, refer to the Under Frequency Roll Off (UFRO) adjustment.
7. Carefully turn VOLTS control clockwise until rated voltage is reached.
8. If instability is present at rated voltage, refer to stability adjustment, then re-adjust voltage if necessary.
9. Voltage adjustment is now completed.

STABILITY ADJUSTMENT

The AVR includes a stability or damping circuit to provide good steady state and transient performance of the generator.

The correct setting can be found by running the generator at no load and slowly turning the stability control anti-clockwise until the generator voltage starts to become unstable.

The optimum or critically damped position is slightly clockwise from this point (i.e. where the machine volts are stable but close to the unstable region).

UNDER FREQUENCY ROLL OFF (UFRO) ADJUSTMENT

The AVR incorporates an underspeed protection circuit which gives a volts/Hz characteristic when the generator speed falls below a presettable threshold known as the "knee" point.

The red Light Emitting Diode (LED) gives indication that the UFRO circuit is operating.

The UFRO adjustment is preset and sealed and only requires the selection of 50 / 60Hz using the jumper link.

For optimum setting, the LED should illuminate as the frequency falls just below nominal, i.e. 47Hz on a 50Hz system or 57Hz on a 60Hz system.